

INSTRUCTIONS FOR VARILIGHT V-PRO DIMMERSWITCHES



OVERVIEW

Thank you for choosing a VARILIGHT V-Pro intelligent programmable dimmerswitch. Use only on an electricity supply of 200-250 volts AC. **IMPORTANT:** Read ALL sections below before installing this dimmerswitch.

V-Pro dimmers are set to run in trailing-edge mode (MODE 1) by default. This versatile mode is suitable for most types of lighting, including many dimmable LEDs. It is also gentler on the load.

An alternative trailing-edge mode (MODE 3) may improve the performance of some dimmable LEDs and dimmable CFLs. Some other lighting loads, including some types of LED, perform best with leading-edge control. This dimmer can also be set to run in leading edge (MODE 2) with certain types of LED light. To change the mode, follow the instructions under "Programming" below.

To optimise the dimming range for LED lighting in particular the minimum brightness setting of the dimmer can be adjusted [see "Adjusting the Minimum Brightness" under "Programming"].

This product complies with European Safety Regulations (IEC 669-2-1 or BSEN 60669-2-1) when used in lighting circuits containing MCBs (miniature circuit breakers). These can be rated at 6A, 10A or 16A (preferably 6A for lighting circuits). Your guarantee is not affected if you have an older lighting circuit protected by fuse wire links.

LOADING

Maximum loads for V-Pro dimmerswitches (please see www.varilight.co.uk for latest loading advice):

Always observe the recommended maximum load.

| Dimmer Series | V-Pro Grid Dimmer Push On/Off | V-Pro Standard Dimmer Push On/Off | | | |
|--|--|-----------------------------------|-----------------|-----------------|-----------------|
| | Multi Gang Per Gang | 1-Gang | 2-Gang Per Gang | 3-Gang Per Gang | 4-Gang Per Gang |
| Lighting Type | | | | | |
| Mains Halogen | 120W | 300W | 200W | 200W | 200W |
| Low Voltage Halogen (Max. 10 transformers per gang) | 120W | 300W | 200W | 200W | 200W |
| Eco Halogen | 120W | 300W | 200W | 200W | 200W |
| Maximum of 10 lamps for GLS and Halogen loads | | | | | |
| Dimmable LED | 1 to 10 LEDs (max. 120W) For the latest advice, visit www.varilight.co.uk/leds | | | | |
| Dimmable CFL | For 1 to 8 Digiflux CFLs Use MODE 3: Digiflux Mode [see "Programming"] For the latest advice, visit www.varilight.co.uk/digiflux | | | | |

MIXED LOADS

- Please adhere to 'Dimmable LED' advice when using mixed loads

THIS SWITCH IS SUITABLE FOR

- ✓ Dimmable LED Lighting
- ✓ Mains voltage incandescent GLS or candle-shaped bulbs
- ✓ Good quality dimmable electronic low voltage transformers (including those requiring trailing-edge control) [see "Transformers"]
- ✓ GU10 or similar good quality mains halogen bulbs
- ✓ Digiflux Dimmable CFLs

THIS SWITCH IS NOT SUITABLE FOR

- * Non-dimmable LED lighting
- * Non-dimmable fluorescent bulbs and tubes
- * Wire-wound or toroidal transformers
- * Electric motors (e.g. Fans)

OVERLOAD PROTECTION:

This dimmerswitch is protected against overload. If an overload occurs it will automatically turn off until the overload is removed and the dimmerswitch is switched off and then switched back on again. However, if the dimmerswitch receives a total short-circuit it may be damaged beyond repair.

| | |
|---|------------|
| www.varilight.co.uk customerservices@varilight.co.uk | J_P |
| Please record the batch number printed on the side of the plastic moulding on the rear of the product. This will assist us in providing any technical support you may require. | |
| BATCH NO: | Reg. JP002 |
| Version 13C & later | |
| INSTALLERS – Please leave these instructions with your customer for future reference. | |

LOADING (Continued)

TRANSFORMERS

Use only with quality dimmable **electronic** transformers. For optimum performance choose VARILIGHT transformers. Do **not** use with wirewound or toroidal transformers.

To calculate load, add the VA ratings of the **transformers (not the wattage of the bulbs)**. Choose transformers with a maximum rating close to their lamp load (e.g. Use a 50VA, 60VA or 70VA transformer to control a 50W low voltage bulb).

N.B. Certain transformers **may not behave according to their power rating when used with a dimmer**. An overload will result in the safety features switching the dimmer off. If so, change your transformer(s) (VARILIGHT transformer(s) recommended); or remove one (or some) transformer(s) from the circuit; or choose a higher rated dimmer.

FREQUENTLY ASKED QUESTIONS

For FAQs, please visit: www.varilight.co.uk/faqs

10 YEAR GUARANTEE

Varilight undertakes to repair or replace, at its discretion, goods which have become defective within 10 years of purchase, solely as a result of faulty materials and workmanship, provided that:-

- a) The unit has been correctly fitted according to the instructions and has not been used with an incompatible load, fluorescent tubes, or overloaded beyond its rating, and has only been used on a 200-250V a.c. power supply.
- b) The dimmer module has not been tampered with or taken apart. However, for your convenience, it is perfectly in order to remove a faulty dimmer module from multi-gang dimmers by pulling off the knob and unscrewing the nut under the knob. You will then still have the remaining modules working whilst we service your faulty module.
- c) The unit is securely packed and safely returned to:-
Customer Services, Caryl's Lea, Faygate, Horsham, West Sussex, RH12 4SJ (Tel. (01293) 851584) together with a letter stating the guarantee registration number below, the date and place of purchase, the type and wattage of the lighting or other load being controlled and the details of the fault.

This guarantee states Varilight's entire liability, which does not extend to cover consequential loss or damage or installation costs arising from a defective product. The guarantee does not apply to problems arising from any incompatibility between your lamps and the dimmer switch. This guarantee does not in any way affect the statutory rights of the purchaser and is offered so that you may have the benefit of our technical facilities.

GUARANTEE REGISTRATION NUMBER: JP002

WARNING: Do not apply products with metal faceplates directly to freshly plastered or damp surfaces as product may tarnish. If in doubt, use polythene as a temporary gasket to protect the product. Do not use masking tape on metal faceplates.

FITTING YOUR DIMMERSWITCH

Read the instructions below carefully. Incorrect installation may damage the dimmer beyond repair. **In case of any doubt or difficulty consult a qualified electrician.**

1. Switch off at the mains, then remove the existing switch and disconnect the wiring from the switch terminals at the rear, taking note of the present wiring of the switch and the marking on the terminals. Where there are two or more wires together in the old switch, they must be kept together in the dimmerswitch.
2. Ensure that any wall box is free of plaster lumps or projecting screw heads. Dimmerswitches on single-sized plates can be fitted to wall boxes having 60.3mm screw fixing centres and those with double-sized plates to wall boxes with 120.6mm fixing centres. Most models can be fitted into a box with a minimum depth of 25mm. A box having 4 fixing lugs cannot be used without modifying it. The top and bottom lugs must be broken off or bent flat.
3. To connect the wiring for 1-way or 2-way circuits refer to the diagrams to the right under the heading "1-Way, 2-Way and Multi-Way Circuits". Take care that no bare wires project out of the terminals. Keep wires together in a terminal if they were together in your old switch.
4. Dimmerswitches having a metal plate must be earthed by means of the earthing point on the dimmer.
5. After connecting the wires screw the dimmerswitch gently into the wall box so that the front plate is not distorted or cracked. Do not trap the wiring between the rear of the dimmer and the back of the wall box.
6. Once installation is complete. Switch on the mains supply and switch on the dimmer.

Important: Disconnect the dimmer before carrying out insulation resistance testing. Failing to do so could damage a dimmer and make the guarantee invalid.

PROGRAMMING

OPTIMISING THE PERFORMANCE OF YOUR DIMMERSWITCH

When you first install the dimmer switch it will automatically default to trailing-edge MODE 1. This mode is the best one for most types of lighting but for some lighting loads you may be able to improve the dimming performance by changing the driving mode. [See "Changing the driving mode" below.] You can always reset to trailing-edge MODE 1. Additionally, the minimum brightness setting of the dimmer can be adjusted to achieve the optimum dimming range for a particular load as follows. (You may also need to refer to these instructions if you change your lights to a different type at a later date so please keep them for reference).

ADJUSTING THE MINIMUM BRIGHTNESS

If your lights are flickering when they are dimmed to a low level you can increase the minimum brightness setting of the dimmer, which may prevent this from happening. If the lights are brighter than you would like when the dimmer is set to minimum, you can try reducing the minimum brightness setting of the dimmer.

1. Switch on and set the dimmer knob to the MINIMUM position (turn fully anti-clockwise).
2. Turn the lights off and back on again. OFF – ON, roughly once per second.
3. Repeat step 2 at least twice more. OFF – ON – OFF – ON, roughly once per second.
4. The lights will step up and down in brightness to show that the dimmer is in CONFIGURATION MODE, then either stay at a low light level or go off.
5. Turn the knob fully clockwise. The lights will come on and allow you to adjust the minimum brightness.
6. Adjust the brightness that you are happy with as the minimum. Leave the dimmer in this position.
7. After 3 seconds the dimmer will notice that you have stopped adjusting the minimum. The lights will step up and down in brightness to show that the dimmer has returned to normal operation.
8. Continue to use the dimmer as normal, with your new minimum brightness.

CHANGING THE DRIVING MODE

You may be able to improve the performance of your lamps by changing the driving mode to MODE 3, or with some types of lamp MODE 2.

NB. It has been noted that some LEDs do not show the programming as well as others. If you are having difficulty seeing the programming steps, you can replace one LED lamp with a halogen one for the duration of the programming in order to see the steps more clearly.

1. Switch on and set the dimmer knob to the MAXIMUM position (turn fully clockwise).
2. Turn the lights off and back on again. OFF – ON, roughly once per second.
3. Repeat step 2 at least twice more. OFF – ON – OFF – ON, roughly once per second.
4. The lights will step up and down in brightness to show that the dimmer is in CONFIGURATION MODE, then either stay at a low light level or go off.
5. To select MODE 3, first turn the knob fully anti-clockwise then fully clockwise. For MODE 2, just turn the knob fully anti-clockwise.
6. The lights will FLASH 3 TIMES or TWICE to show which mode the dimmer is in. The dimmer can be operated normally in the new mode.

PROGRAMMING (Continued)

N.B. The dimmer is designed to protect itself against excess current. Some types of LED light will draw too much current in MODE 2. In this case the dimmer will switch back automatically to MODE 1. The dimmer will turn off altogether if it is overloaded in MODE 1 or MODE 3.

To manually return the dimmer to MODE 1 follow the same procedure and at step 5 turn the knob fully anti-clockwise. The lights will FLASH ONCE to indicate that you have successfully returned the dimmer to MODE 1.

[To check which mode the dimmer is operating in omit step 5.]

RESETTING THE DIMMER

If you change your lights you can reset the dimmer to the factory default minimum brightness setting and re-launch trailing-edge mode 1 as follows.

1. Switch on and set the dimmer knob to the MAXIMUM position.
2. Turn the lights off and back on again. OFF – ON, roughly once per second.
3. Repeat step 2 at least twice more. OFF – ON – OFF – ON, roughly once per second.
4. The lights will step up and down in brightness to show that the dimmer is in CONFIGURATION MODE, then either stay at a low light level or go off.
5. Within 5 seconds, repeat steps 2 and 3. OFF – ON – OFF – ON – OFF – ON, roughly once per second.
6. The dimmer will reset all its settings to factory defaults. The lights will come on, then fade away to off.
7. The dimmer will now operate in trailing-edge mode 1 and the minimum brightness setting will be reset to the factory default.
8. Continue to use the dimmer as normal.

1-WAY, 2-WAY AND MULTI-WAY CIRCUITS

Your VARILIGHT V-Pro intelligent dimmerswitch is suitable for 1-way or 2-way lighting circuits. It has a push on/push off action to switch and a rotary action to dim. There are 3 screw terminals per module.

1-WAY CIRCUITS

In 1-way lighting circuits each light is controlled by one switch.

Your dimmerswitch should replace this switch. See Figure 1. Remove your old switch and copy the wiring configuration for your dimmerswitch. Connect wires either way round to the 'C' terminal and one of the 'L' terminals. The other 'L' terminal is not used in a 1-way circuit.

2-WAY CIRCUITS

2-way lighting circuits have two switches turning the same lights on and off from 2 different locations (eg. at the top and bottom of the stairs). You must only replace one of these switches with a dimmerswitch or the lights will flicker. See Figures 2 and 3 which show typical 2-way circuits. Remove your old switch and copy the wiring configuration for the dimmer. The wire(s) fitted in the "common" terminal of the old switch should be fitted into the "C" terminal of the dimmerswitch. The wires fitted into the other two terminals of the old switch should be fitted either way round into terminals "L1" and "L2" of the dimmerswitch.

MULTI-GANG DIMMERSWITCHES

To fit 2 gang (or 3 or 4 gang) dimmerswitches treat each group of terminals at the back of the unit as a separate dimmerswitch wiring them into the lighting circuits as described above. If required, one terminal from each dimmer module may be joined together with a short length of wire to copy the wiring configuration of the old switch.

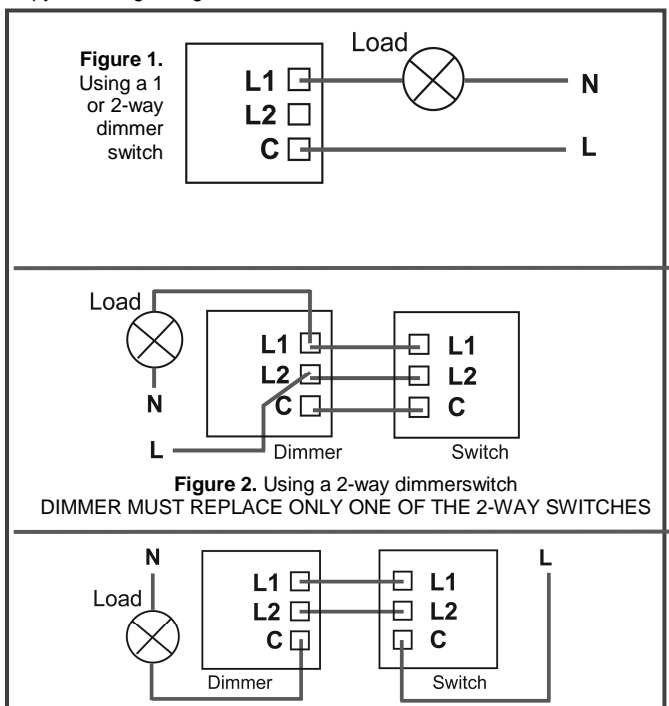

Figure 3. Using a 2-way dimmerswitch DIMMER MUST REPLACE ONLY ONE OF THE 2-WAY SWITCHES